

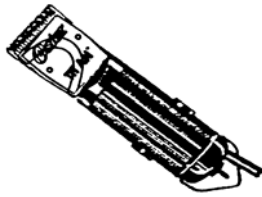

PARTS LIST

"CLASSIC 76" CLIPPER



INSTRUCTIONS	COL. NO.
106349	1

USE ONLY GENUINE OSTER PARTS
USE OF WRONG PARTS MAY BE HAZARDOUS.

106349-G Revised 11/27/07

NEW MODELS ADDED	⇔	FIRST ISSUE	7/00	COLUMN #:															
SINGLE SPEED			X	X															
BLACK				X															
BURGUNDY			X																
120 VOLTS, 45 WATTS, AC			X	X															
MODEL OR SERVICE NO. COLUMN	→	1	2	3	4	5	6	7	8	9	10	11							

INDEX NO.	PART NUMBER	* WAS PART NO.	DESCRIPTION	Basic Parts	QUANTITY REQUIRED															
					076076-010-000	076076-210-000														
1	106942-000-000		SCREW,#6X1/2,TWIN HELIX	2																
2	105179-000-000		COVER PLATE		1															
2	105184-000-000		COVER PLATE			1														
3	041676-000-000		OILER	1																
4	042563-000-000		OIL WICK	1																
5	109547-000-000		CAPTURE PLATE (NOT SHOWN)	1																
6	044946-005-000	044946-000-000	LEVER	1																
7	045515-000-000		LINK	1																
8	041723-000-000		GREASE SEAL	2																
9	111012-020-000		BRUSH CAP-BURGUNDY		2															
9	111012-010-000		BRUSH CAP-BLACK			2														
10	042584-025-000		BRUSH & SPRING ASSY	2																
11	042566-000-000		THRUST PLATE	1																
12	058908-000-000		GEAR	1																
13	057022-005-000	108783-020-005	HSG-MOTOR-MACH/BURGUNDY		1															
13	057022-000-000	108783-010-005	HSG-MOTOR-MACH/BLACK			1														
14	058543-000-000		WASHER-THRUST	1																
15	042575-000-000		HINGE ASSEMBLY	1																
16	041665-000-000	109189-000-000	SCREW, MAC #6-32	2																
17	045588-000-000		BLADE GUARD	1																
18	111038-010-000		LABEL,DATA,76-10C		1															
18	111038-080-000		LABEL, DATA			1														
20	042571-000-000		BLADE GUIDE	1																
22	044936-000-000		SOCKET	1																
25	042555-000-000		BLADE SCREW- #6-32 X 7/32	2																
26	057070-000-000		BEARING	2																
27	042568-000-000		WASHER-FELT	2																
29	058519-000-000		BEARING RETAINER	2																
30	042114-050-000		SCREW	2																
31	042872-000-000		Screw - #6-32 X 1/4	2																
32	084934-005-000		ARMATURE ASSY. - 1 SPEED 120V		1	1														
33	084936-000-000	084936-005-000	FIELD ASSY - 120V		1	1														
35	042557-000-000		LOCATING RING	1																
36	042559-000-000		CUP-THRUST SPRING	1																
37	042562-000-000		THRUST SPRING	1																
38	058006-000-000		MOTOR END FRAME ASSY.	1																
42	042570-000-000		RETAINING CUP	1																
44	104365-000-000		SWITCH ASSY-1SPD		1															
45	111013-020-000		VENT(W/SCREEN) BURGUNDY			2														
46	108780-020-000		END CAP,TOGGLE,BURGUNDY		1															
46	108780-010-000		END CAP,TOGGLE,BLACK			1														
47	041756-000-000		LOCKWASHER	2																
48	042574-000-000		SCREW - #6-32 X 1 1/8	2																
49	058168-000-000		SWITCH NUT	1																
50	042614-000-000		BRUSH RETAINER ASSY.	2																
51	042573-000-000		BALE	1																
52	042551-000-000		RETAINING RING	1																
55	110738-000-000		CORD WSR,POLARIZED,96		1															
62	042564-000-000		SCREW- #4-36 X 3/16	2																
74	041680-000-000		GREASE 1 LB																	
75	042113-015-000		SCREW-BT	3																
79	058355-000-000		TERMINAL BRACKET	2																
	042555-00000		SCREW	2																
	041877-510-003		BLADESET		1															
	041877-540-003		BLADESET			1														
	041877-010-003		BLADESET				1													
	041877-040-003		BLADESET					1												



END CAP SHOWN ASSEMBLED
- FOR REFERENCE ONLY -

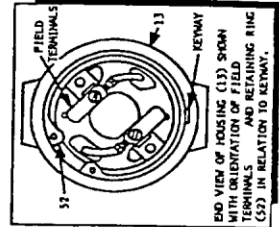
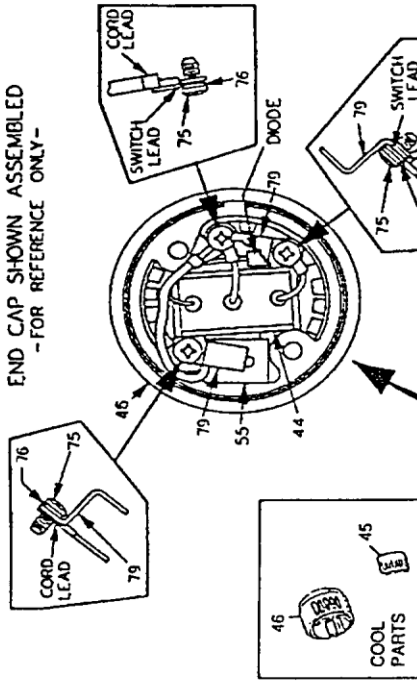

END VIEW OF HOUSING (13) SHOWN WITH ORIENTATION OF FIELD TERMINALS (52) AND RETAINING RING (53) IN RELATION TO KEYWAY.

CAUTION: NUMBERS SHOWN ON DRAWING ARE INDEX NUMBERS ONLY. ORDER PARTS BY CORRECT PART NUMBER.

VIEW 2

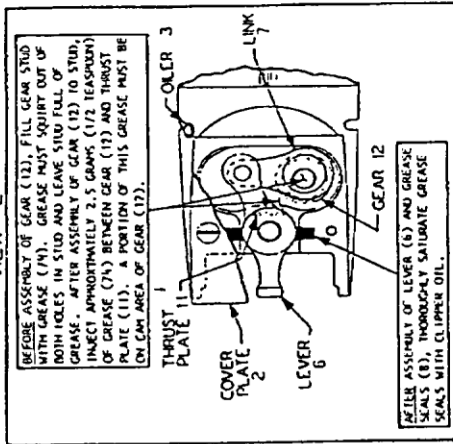

BEFORE ASSEMBLY OF GEAR (12), FILL GEAR SLOD WITH GREASE (74). GREASE MUST SQUIRT OUT OF BOTH HOLES IN SLOD AND LEAVE SLOD FULL OF GREASE. AFTER ASSEMBLY OF GEAR (12) TO SLOD, INJECT APPROXIMATELY 2.5 GRAMS (1/2 TEASPOON) OF GREASE (74) BETWEEN GEAR (12) AND THRUST PLATE (11). A PORTION OF THIS GREASE MUST BE ON CAM AREA OF GEAR (12).

AFTER ASSEMBLY OF LEVER (6) AND GREASE SEALS (8), THOROUGHLY SATURATE GREASE SEALS WITH CLIPPER OIL.

SEE FRAME B-8, PAGE 2A FOR BLADE SET & TENSION SPRING CHART. BLADE ADJUSTMENT SPECIFICATIONS AND BUSHING & RIVET SET INFORMATION.

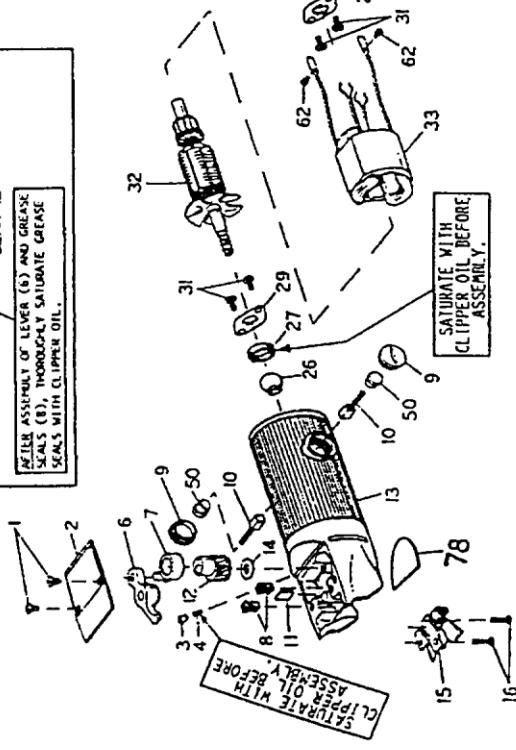
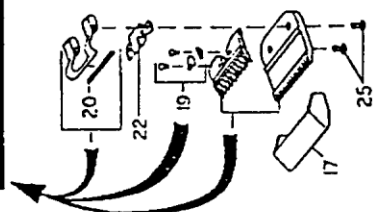

SATURATE WITH CLIPPER OIL BEFORE ASSEMBLY.

EXAMPLE:
THE COMPONENT PARTS (SMALL INDEX NO.'S) ARE INCLUDED WHEN ORDERING THE ASSEMBLY PART (LARGE INDEX NO.)

28	29	30
----	----	----

NOTE: VERTICAL CAM GEAR (12) WITH SMALL PYLE AS SHOWN CAN ONLY BE USED ON THIS MODEL.

NOTE: TO INSURE THAT THE CORRECT APPATURE IS USED WITH THIS MODEL, CHECK THE MARK ON END OF SHANK. THESE SHOULD MATCH THROUGH AND END OF SHANK AS SHOWN.

START THREAD

MARTIN-GOR LTD